

GoFa™ CRB 15000

Go far with your new helping hand

Go faster. Go further than ever. GoFa's class-leading speed, safety, and ease of use will take your business to the next level.



Introducing GoFa

GoFa incorporates a range of features that allow it to be used safely, directly alongside human workers and without the need to design and build bulky barriers or fencing. GoFa can continuously share workspace with people, giving it maximum flexibility and efficiency. Robot and human cooperate on the same tasks, without jeopardizing productivity or safety.

Strong yet safe

Designed for handling payloads up to 5 kg, GoFa has integrated torque sensors in each of its six joints offering superior power and force limiting performance. Together, these prevent the risk of injury by bringing GoFa to an immediate stop if it senses any contact with a human worker.

Easy set-up and operation

Set up and configuration is easy with intuitive, graphical Apps directly on the FlexPendant. You can move your robot using lead through in no time.

Faster performance for greater productivity

GoFa offers a maximum Tool Center Point (TCP) speed of up to 2.2 m/s,* faster than other cobots in its class. GoFa can perform more operations in a set period than competing robots.

Key features:

Collaborative safety

- Superior power and force limiting performance through integrated torque sensors
- Safe design of robot, rounded geometry, no pinch/trap points
- Safety certified Category 3, PL d

Easy to use

- Enhanced interaction with arm side interface
- Lead-through anywhere on the robot
- Wizard easy programming
- SafeMove configurator App on the FlexPendant

Productivity

- With a TCP speed of up to 2.2 m/s,* GoFa is faster than other cobots in its class
- 950 mm reach: 12 per cent longer than comparable 5 kg cobots
- Powered by OmniCore with best-in-class motion control

Applications

- Material handling
- Picking & packaging
- Machine tending
- Screwdriving
- Assembly
- And many more ...

*Safe collaborative speed will be lower, refer to the SafeMove configurator App for recommendation. Always do a safety risk assessment of your cobot application.

Specification

Robot version	Reach (mm)	Payload (kg)	Armload (kg)
CRB 15000	950	5	No armloads*
Number of axes	6		
Protection	IP54		
Mounting	Any angle, including table mounting, wall mounting, and ceiling mounting		
Controller	OmniCore C30		
Customer power supply	24V/2A supply		
Customer signals	4 signals (for IO, Fieldbus, or Ethernet)		
Tool flange	Standard ISO 9409-1-50		
Functional safety	SafeMove Collaborative included All safety functions certified to Category 3, PL d		

*See product specification for details

Performance

Max TCP Velocity	2.2 m/s
Max TCP Acceleration	11.8 m/s ²
Max TCP Acceleration (normal control motion @nominal load)	36.9 m/s ²
Max TCP Acceleration (e-stop @nominal load)	61.6 m/s ²
Acceleration time 0–1 m/s	0.097 s
Pose repeatability	0.05 mm
1 kg picking cycle 25 × 300 × 25 mm	0.66 s

Physical

Dimensions robot base	165 × 165 mm
Weight	27 kg

Movement

Axis movement	Working range	Axis max. speed
Axis 1 rotation	-180° to 180°	125°/s
Axis 2 arm	-180° to 180°	125°/s
Axis 3 arm	-225° to 85°	140°/s
Axis 4 wrist	-180° to 180°	200°/s
Axis 5 bend	-180° to 180°	200°/s
Axis 6 turn	-180° to 180°	200°/s



Working range, Side view

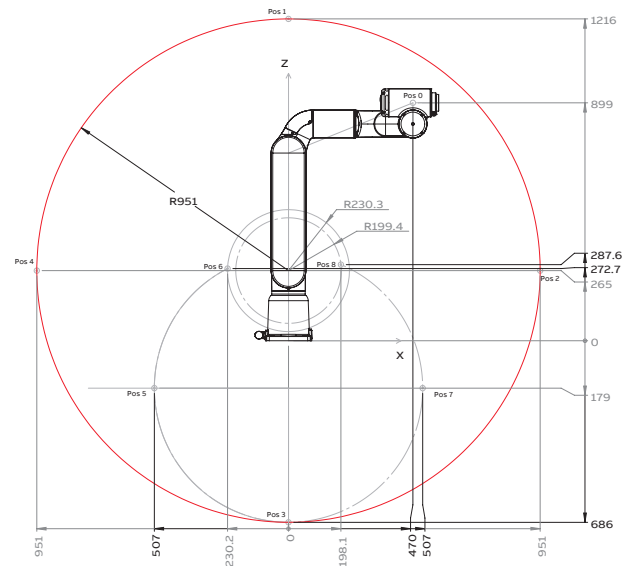

Top view

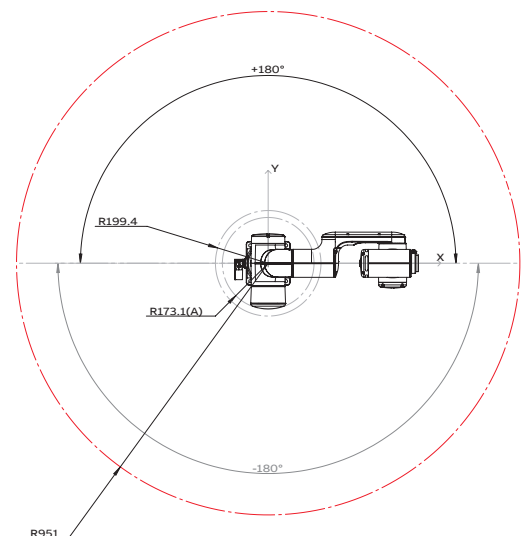

We reserve the right to make technical changes or modify the contents of this document without prior notice. With regard to purchase orders, the agreed particulars shall prevail. ABB does not accept any responsibility whatsoever for potential errors or possible lack of information in this document.

We reserve all rights in this document and in the subject matter and illustrations contained therein. Any reproduction, disclosure to third parties or utilization of its contents – in whole or in parts – is forbidden without prior written consent of ABB. Copyright© 2021 ABB
All rights reserved