

IRB 4600

Industrial Robot



IRB 4600 is a highly productive general purpose robot optimized for short cycle times where compact robots can help create high density cells. The IRB 4600 enables more compact manufacturing cells with increased production output and higher quality - and that means improved productivity.

Shortest cycle times

Thanks to the new compact and optimized design resulting in a low weight, the IRB 4600 can cut the cycle times of the industry benchmark by up to 25%. The maximum acceleration achievable is highest in its class, together with high maximum speeds. With the high acceleration it is possible to use to avoid obstacles or to follow the path. The benefit is increased production capacity and higher productivity.

Ultra-wide working range

You can position the IRB 4600 in the most favourable way with regard to reach, cycle time and auxiliary equipment. Flexible mounting with floor, tilted, semi-shelf or inverted mounting is very useful when you are simulating the best position for your application.

Compactness

The small footprint, the slim swing base radius around axis 1, the fine elbow behind axis 3, the small lower and upper arms, and the compact wrist all contribute to the most compact robot in its class. With the IRB 4600 you can create your production cell with reduced floorspace by placing the robot closer to the served machines, which also increases your output and your productivity.

Best protection available

ABB has the most comprehensive protection program on the market and it will be even further enhanced with the IRB 4600. Foundry Plus includes

IP 67, resistant paint, rustprotected mounting flange and protection for molten metal spits on non-moving cables on the rear of the robot and extra protection plates over the floor cable connections on the foot.

Optimize and go sharp

To get the IRB 4600 ready for the targeted applications you have access to high performing workpiece positioners, track motions, and the motor and gear unit range.

To simulate your production cell to find the optimal position for the robot and program it offline, RobotStudio is available on subscription together with PowerPacs for several applications.

Learn more about how to use the IRB 4600 in your applications and environments - watch simulations on several applications at www.abb.com/robotics.

Main applications

- Arc Welding
- Assembly
- Material Handling
- Machine Tending
- Material Removal
- Cleaning/Spraying
- Dispensing
- Packing
- Laser Cutting
- Laser Welding

Specification

Robot version	Reach (m)	Payload (kg)	Armload (kg)
IRB 4600-60/2.05	2.05	60	20
IRB 4600-45/2.05	2.05	45	20
IRB 4600-40/2.55	2.55	40	20
IRB 4600-20/2.50	2.51	20	11
Number of axes	6+3 external (up to 36 with MultiMove)		
Protection	Standard IP67, as option Foundry Plus 2		
Mounting	Floor, shelf, inverted or tilted		
Controller	IRC5 Single cabinet		

Performance (according to ISO 9283)

	Position repeatability	Path repeatability*
IRB 4600-60/2.05	0.06 mm	0.46 mm
IRB 4600-45/2.05	0.05 mm	0.13 mm
IRB 4600-40/2.55	0.06 mm	0.28 mm
IRB 4600-20/2.50	0.05 mm	0.17 mm

*Measured at speed 250 mm/s.

Technical information

Electrical Connections

Supply voltage 200-600 V, 50-60 Hz

Physical

Robot base 512 x 676 mm

Height

IRB 4600-60/2.05 1727 mm

IRB 4600-45/2.05 1727 mm

IRB 4600-40/2.55 1922 mm

IRB 4600-20/2.50 1922 mm

Robot weight

IRB 4600-60/2.05 425 kg

IRB 4600-45/2.05 425 kg

IRB 4600-40/2.55 435 kg

IRB 4600-20/2.50 412 kg

Environment

Ambient temperature for mechanical unit

During operation +5° C (41° F) to + 45° C (113° F)

During transportation and storage -25° C (-13° F) to +55° C (131° F)

During short periods (max. 24 h) up to +70° C (158° F)

Relative humidity Max. 95%

Safety Double circuits with supervisions, emergency stops and safety functions. 3-position enable device

Emission EMC/EMI shielded

Data and dimensions may be changed without notice.

Movement

Axis movement	Working range	Axis max. speed
Axis 1 rotation	+180° to -180°	175°/s
Axis 2 arm	+150° to -90°	175°/s
Axis 3 arm	+75° to -180°	175°/s
Axis 4 wrist	+400° to -400°	250° (360° for IRB 4600-20/2.50)
Axis 5 bend	+120° to -125°	250° (360° for IRB 4600-20/2.50)
Axis 6 turn	+400° to -400°	360° (500° for IRB 4600-20/2.50)

Working range, IRB 4600-60/2.05, IRB 4600-45/2.05

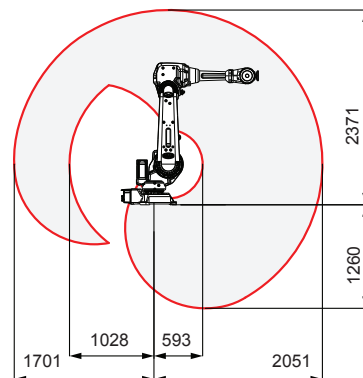

Working range, IRB 4600-40/2.55

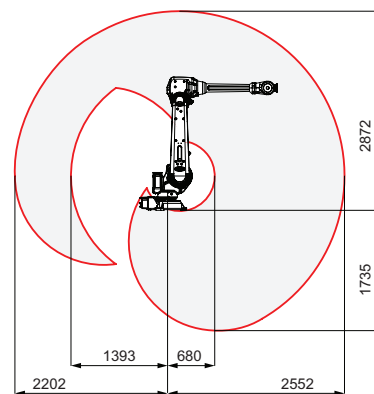

Working range, IRB 4600-20/2.50

